

## Broadcom<sup>®</sup> Energy Efficient Networking

Broadcom continues to drive innovation in communications technologies through leadership in and contribution to the development of standards. Broadcom is embracing the IEEE Std 802.3az™-2010 Energy Efficient Ethernet™ (EEE) standard as part of its broad framework to achieve high-performance and low-power technologies at an optimal cost point across its wired Ethernet portfolio.

Broadcom<sup>®</sup> Energy Efficient Networking builds upon the requirements of the standard by adding control policy as well as hardware and software subsystems in a standards-friendly way. Energy Efficient Networking enables Broadcom customers to build complete energy-efficient systems with enhanced energy savings at a faster time-to-market.

October 2010



## Traditional Versus Next-Generation Networks

Traditional networks have optimized cost and performance. Broadcom's next-generation networking solutions will add optimized power consumption to make the network energy-efficient.

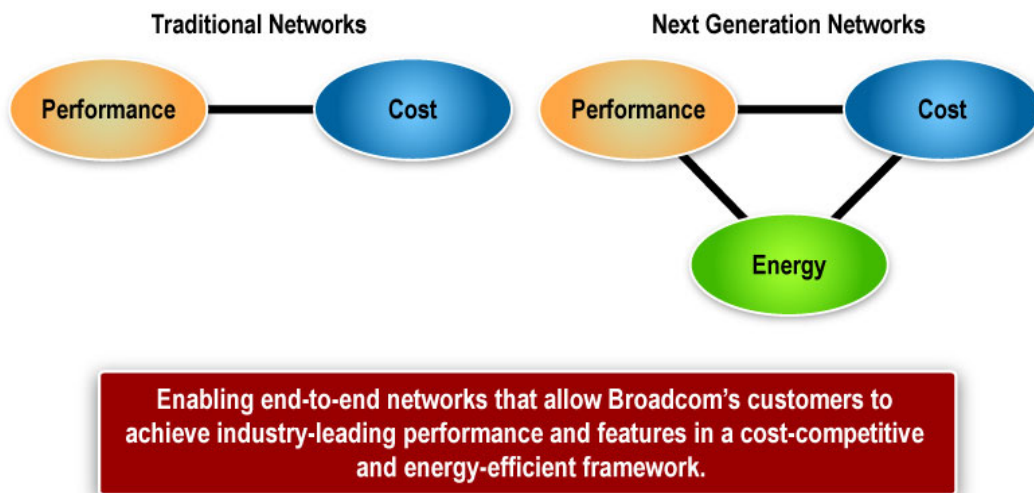

**Figure 1: Cost-Performance-Power Model for Traditional Networks vs. Next-Generation Networks**

## What Is IEEE 802.3az-2010 Energy Efficient Ethernet?

IEEE 802.3az-2010, which was ratified on September 30, 2010 and is also known as Energy Efficient Ethernet, is targeted at saving energy in Ethernet networks for a select group of PHYs. The PHYs selected in this project include the popular 100BASE-TX and 1000BASE-T PHYs, as well as emerging 10GBASE-T technology and backplane interfaces, such as 10GBASE-KR. The method of power savings currently planned for these PHYs is a technique known as Low Power Idle (LPI).

The legacy Ethernet standards for interfaces of 100M and higher have an active idle state, which requires the bulk of the circuitry to remain powered up, independent of data transmission. This results in comparable power consumption regardless of whether there is data on the link. LPI provides for a lower-consumption energy state that can be employed during periods of low-link utilization (high idle time), which is common in many Ethernet networks. LPI allows for rapid transitions back to the active state for high-performance data transmission.

## Wide Applicability of EEE

Ethernet has become the ubiquitous technology of choice for wired connectivity. Indeed, Ethernet is being deployed in enterprise, Small-to-Medium-Sized Business (SMB), service provider, and home networks as well as professional AV networks. It is also prevalent in data centers and storage applications. As such, all areas of the network stand to benefit from EEE energy savings.

## High Potential for Energy Savings

Typical Ethernet traffic profiles have characteristically low average link utilization over time with occasional bursts that are associated with network activity. This lends itself very well to EEE which takes advantage of the high percentage of idle time on the link (see Figure 2).

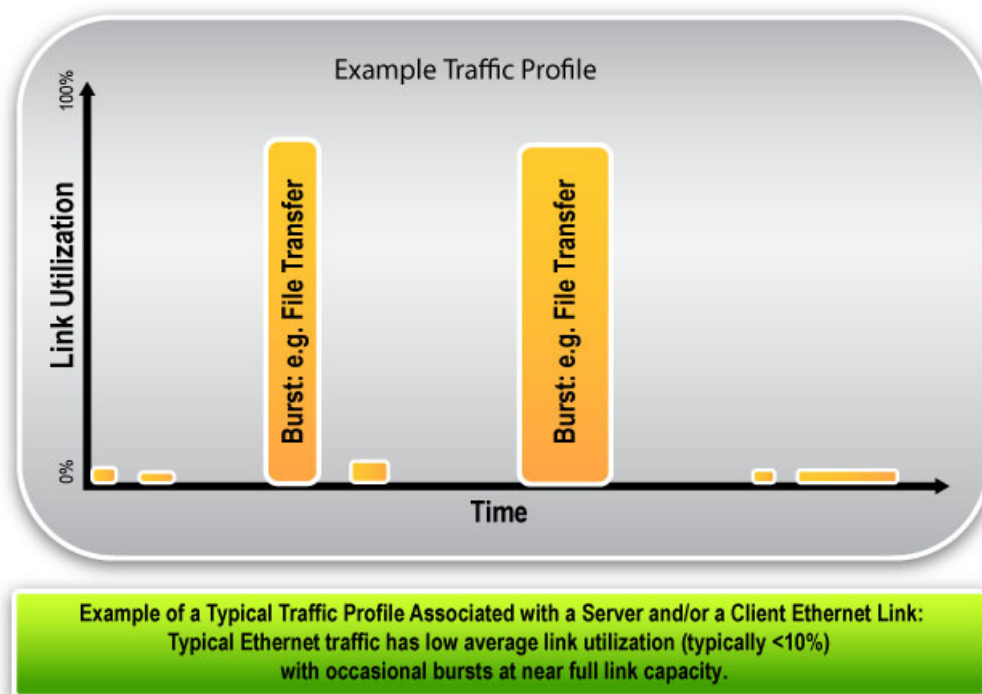

**Figure 2: Typical Traffic Profile Example**



Ethernet traffic profiles will vary based on application and market segment. By using EEE in conjunction with the Broadcom control policy technology described below, end customers can take advantage of the network idle times to realize high levels of power savings.

### **Broadcom Energy Efficient Networking: End-to-End Energy Efficient Framework and Savings**

Broadcom's emerging physical layer products are on the cutting edge of energy savings, and the controller and switch products allow for additional savings beyond that, which can be accomplished by only using EEE's LPI and beyond the physical layer.

### **A Framework for "Green" Networking**

The following equation is a simple but powerful framework used to understand how the energy is consumed and ultimately how the savings occur.

$$\mathbf{E_T} = [\mathbf{P_{active}} * \mathbf{T_{active}}] + [\mathbf{P_{idle}} * \mathbf{T_{idle}}]; \quad \text{where } \mathbf{T} = \mathbf{T_{active}} + \mathbf{T_{idle}}$$

$\mathbf{E_T}$  represents the amount of energy consumed over a period of time, represented by  $\mathbf{T}$ . If you think of your monthly energy bill, this would proxy the meter reading month over that month, with  $\mathbf{T}$  being a month and  $\mathbf{P}$  being power consumption. The higher is  $\mathbf{E}$  over a period of time, the more energy is consumed and the higher is the bill (for example, cost in \$, Euros, or Yen). To maximize the savings, this equation must be minimized.

Assume that a networking device has two states, an active state and an idle state. The total energy consumed would be the energy consumed while the device is in that active state added to the energy consumed when it is in the idle state. Going back to fundamentals, the energy in any state can be described as the product of the average power consumption in that state by the duration in the state.



To minimize the power consumption<sup>1</sup>, or precisely stated, maximize the power savings, three factors emerge:

- Minimize  $P_{\text{active}}$
- Minimize  $P_{\text{idle}}$
- Maximize  $T_{\text{idle}}$ <sup>2</sup>

To tie back the equation to EEE, consider what EEE provides to networking systems. Unlike a stand-alone system, networking systems communicate with their link partners. EEE fundamentally provides a method to move a networked system from an active state to an idle state without compromising network connectivity or remarkably impacting upper layer protocols. In essence, it provides the second set of terms in the equation.

### **Broadcom's Innovations Described Within the Framework**

There are two additional components that are essential to building EEE systems and networks that are beyond the scope of the standard but are critical to EEE-enabled devices:

- **EEE Control Policy:** Provides controls when the physical layer enters and exits the low-power state and is outside the scope of standard. The level of integration of the control policy decision engine with the controls to the physical layer will affect the overall efficiency attained. Moreover, the control policy maximizes savings by maximizing the time the system spends in  $T_{\text{idle}}$  while minimizing any performance impact on the network.
- **Enhanced Savings:** Provides enhanced savings in the device that extend beyond the physical layer at either the transmitting link partner or receiving link partner (See Figure 3). This involves reducing both  $P_{\text{active}}$  and  $P_{\text{idle}}$ .

---

<sup>1</sup> Naturally, this equation can be expanded to take into account a more complex system with multiple energy states for the device. In that case, it would be the weighted average of the power states multiplied by the time the device spends in that state. Nonetheless, the principles of conservation remain the same.

<sup>2</sup> Since the total time is the sum of the time in idle and active, maximizing idle is the equivalent of minimizing the time in the active state.

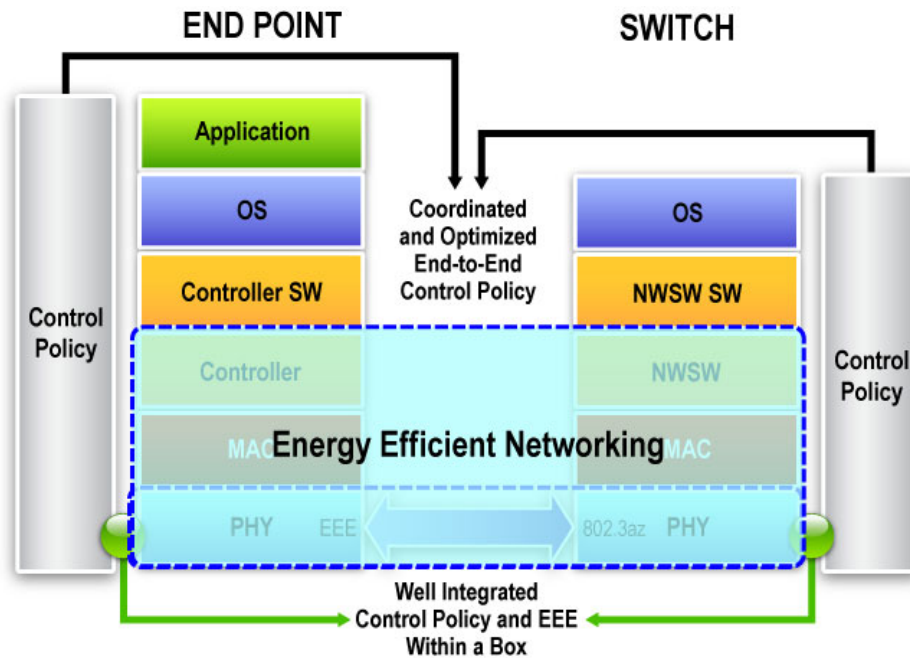

**Figure 3: Additional Power Savings Enabled by Broadcom Energy Efficient Networking**

Figure 3 represents an edge device (e.g., server or client) connected to a node (such as a switch) within a network. The devices are connected via an EEE-enabled Ethernet link. The figure breaks each link partner into its significant subsystems in an OSI-like fashion starting with the physical layer at the bottom, labeled "PHY", and moving up through the stack. Figure 3 also illustrates the additional power savings enabled through Broadcom's standards-friendly Energy Efficient Networking enhancements. The principles also apply in a switch-to-switch connection.

### **Broadcom Energy Efficient Networking: Control Policy Approach**

The control policy spans more than just one layer as the decision to go into and out of the energy saving state will require the management system of the device to act based upon a number of inputs.

The control policy must be customized for the particular application to yield optimal savings, and this can be done with Broadcom software. In addition, the Broadcom software stack allows for programmability for different levels of performance and energy savings options.



## **Introducing AutogrEEEn™ Technology**

To allow for rapid market adoption and immediate customer transition to EEE-enabled ports, Broadcom has introduced AutogrEEEn™ technology as a part of its EEE PHY lineup. AutogrEEEn technology enables a device with a non-EEE MAC to seamlessly transition to EEE capabilities by implementing control policy assist engines and circuitry inside the PHY device.

EEE requires control for the PHY completion via in-band signaling over the MAC/PHY interface. This requires a change to both the PHY and MAC silicon. A number of systems have the MAC and PHY as two different pieces of silicon with the MAC often embedded in a switching or controller-type device. These MAC-containing devices have associated drivers and software, and are often multiport devices. So, a transition to EEE may be hampered by additional development that involves replacement of the MAC-containing devices.

Broadcom's AutogrEEEn technology eliminates the need to change the MAC/PHY interface on the MAC silicon, and allows for rapid transition today with legacy non-EEE MAC silicon attached to Broadcom AutogrEEEn-enabled PHYs.

## **Conclusion**

This paper introduced Broadcom Energy Efficient Networking, which builds upon the IEEE 802.3az-2010 EEE standard in the following ways:

1. Comprehensive control policy.
2. Additional energy savings: Putting additional resources "to sleep" beyond the PHY by taking advantage of the EEE low-power state.
3. Software will play a key role in maximizing energy savings in various applications and spaces, allowing for optimized energy savings and a control policy that can be customized.



## **About the Author**

Wael William Diab is currently a Technical Director in Broadcom's Office of the CTO working on technical strategy for the Infrastructure and Networking Group (ING).

Wael is a Senior Member of the IEEE and was elected as the Vice-Chair of the IEEE 802.3 Ethernet Working Group. Wael is a member of the IEEE-SA Standards Board's RevCom and AudCom Committees and has been elected to the IEEE-SA CAG (Corporate Advisory Group). He is a member of the IEEE Standards Education Committee (SEC) and is a published author, coauthoring Ethernet in the *First Mile: Access for Everyone*, a book published by the IEEE, and was a contributing author to *Broadband Services: Business Models and Technologies for Community Networks*.

Wael holds BS and MS degrees in Electrical Engineering from Stanford University, a B.A. degree in Economics from Stanford, and an M.B.A. with honors from the Wharton School of Business. He has developed over 200 patents/patents-pending in the networking space.



Phone: 949-926-5000  
Fax: 949-926-5203  
E-mail: [info@broadcom.com](mailto:info@broadcom.com)  
[www.broadcom.com](http://www.broadcom.com)  
EEE-WP101-R  
October 2010

Broadcom®, the pulse logo, Connecting everything®, and the Connecting everything logo are trademarks of Broadcom Corporation and/or its affiliates in the United States, certain other countries and/or the EU. Any other trademarks or trade names mentioned are the property of their respective owners.

Broadcom Corporation  
5300 California Avenue  
Irvine, CA 92617

© 2010 by Broadcom Corporation  
All rights reserved.  
Printed in the U.S.A.